



Product brief

SPOC™+2

Half the size, twice the current: new Infineon configurable SPI Power Controllers

Infineon Technologies AG is launching a new generation of its multichannel SPI high-side power controllers. Today, the SPOC™ family is leading the market for multichannel high-side smart switches in automotive exterior lighting. The new SPOC+2 is designed to address additional applications such as door lock, seat heating, interior lighting as well as lighting and power distribution loads also for e-bikes.

Just like the body control module (BCM) around 15 years ago, other in-car ECUs like junction, fuse and relay boxes now start to become increasingly complex, supporting more features. A number of new features make the SPOC+2 family more flexible to use. For example, previous generations were equipped with two pre-defined modes for either bulb or LED loads. Now, important parameters including slew rate, load current sense accuracy (KILIS) and overload detection current can be configured individually for each of the up to six channels. Moreover, this comes without negative effects on the on-state resistance RDS(ON). Furthermore, the new concept allows two channels to drive one load in parallel. Consequently, the range of supported currents is now twice as wide: 1.5 A to 14 A (previously 1.5 A to 7 A).

With the new generation, customers can easily switch between all products of the SPOC+2 family, for example in case of late requirement changes from an OEM. All products use the same pin-out-logic, a common software concept and now also the same package. Compared to the previous generation, Infineon reduced the package size for the high-end product BTS72220-4ESA/E by more than 50 percent. Therefore, with a body-size of 52 mm² all products of the SPOC+2 family are less than half as big as alternative devices on the market.

SPOC+2 products come with an integrated diode, which allows an easier and cheaper solution on system level (for network grounding). No additional diode is needed and a much smaller resistor can be used (100 Ω down to 47 Ω). The new product family offers additional configurable protection features, which can be applied individually for each channel. Besides state-of-the-art functions like short-circuit and overload protection, SPOC+2 includes a configurable over-load-detection current. The protection can either be configured with limited restart or immediate latch. For all SPOC+2 products Infineon provides a common diagnosis concept via SPI. The products include enhanced diagnosis functions such as open load in the off-state and short circuit to battery.

Key features

Protection features

- › Absolute and dynamic temperature limitation, overcurrent protection, undervoltage shutdown, overvoltage protection

Diagnosis features

- › Proportional load current sense, open-load in ON and OFF state, short circuit to ground and battery, diagnosis feedback

Functional safety features

- › Limp home mode, monitoring input status, checksum verification, current sense verification mode

Key benefits

- › Optimized feature to costs
 - PWMoverSPI, best in class KILIS, simple GND network, ReverseOn, cranking, chl. parallelization
- › Low power dissipation
- › Scalability of family devices
- › Significant PCB area reduction

Key applications

- › High-side-switch with diagnosis and embedded protection for automotive application with focus on light-loads, suitable for restive, inductive and capacitive loads to replace electromechanical relays, fuses and discrete circuits



SPOC™+2: SPI power controller

For automotive power-distribution applications:
a new benchmark in flexibility, efficiency and package size

Application diagram

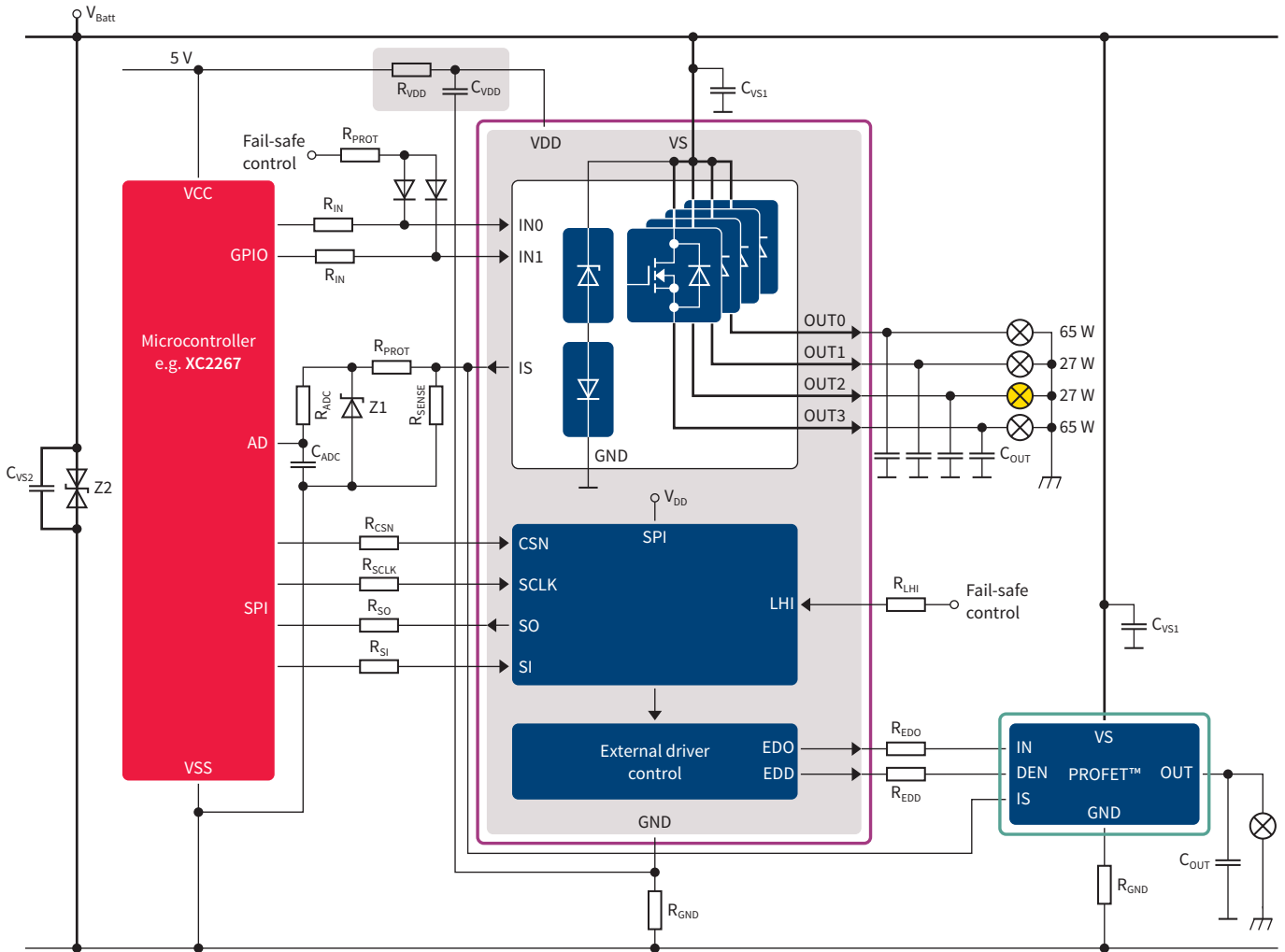

BCM power switches

Main component(s)	IFX product offering
> Multi-channel high-side switch	> SPOC™+2 e.g. BTS72220-4ESx
> High-side switch	> PROFET™+2 e.g. BTS7040-1EPA

BCM communication, control and security

Main component(s)	IFX product offering
> Microcontroller	> AURIX™ XC2267

SPOC™+2: SPI power controller

For automotive power-distribution applications:
a new benchmark in flexibility, efficiency and package size

Product table

Product	No of channels	Channel mix [mΩ]	Bulb capability [W]	LED	Nominal load current [A]	$I_{L(SC)}$ (typ) [A]	External drive	Adjust. slewrate	Operating voltage [V]	ReverSave™	Limp home	Package ¹⁾
BTS72220-4ESA	4	2 x 5.5 + 2 x 13.5	2 x 65 + 2 x 42	Yes	2 x 7 + 2 x 4	118/63		●	3.3...5	●	●	TSDSO-24
BTS72220-4ESE	4	2 x 5.5 + 2 x 13.5	2 x 65 + 2 x 42	Yes	2 x 7 + 2 x 4	118/63	●	●	3.3...5	●	●	TSDSO-24
BTS71220-4ESA	4	2 x 9.5 + 2 x 22.5	2 x 55 + 2 x 27	Yes	2 x 5 + 2 x 3	90/48		●	3.3...5	●	●	TSDSO-24
BTS71220-4ESE	4	2 x 9.5 + 2 x 22.5	2 x 55 + 2 x 27	Yes	2 x 5 + 2 x 3	90/48	●	●	3.3...5	●	●	TSDSO-24
BTS71040-4ESA	4	4 x 22.5	4 x 27	Yes	4 x 3	48		●	3.3...5	●	●	TSDSO-24
BTS71040-4ESE	4	4 x 22.5	4 x 27	Yes	4 x 3	48	●	●	3.3...5	●	●	TSDSO-24
BTS71033-6ESA	6	3 x 30 + 3 x 70	3 x 27 + 3 x 10	for 27 W	3 x 2.5 + 3 x 1.5	48/22		●	3.3...5	for 27 W	●	TSDSO-24

1) Footprint: 51.9 mm², pin pitch: 0.65 mm



Published by
Infineon Technologies AG
81726 Munich, Germany

© 2018 Infineon Technologies AG.
All Rights Reserved.

Please note!

THIS DOCUMENT IS FOR INFORMATION PURPOSES ONLY AND ANY INFORMATION GIVEN HEREIN SHALL IN NO EVENT BE REGARDED AS A WARRANTY, GUARANTEE OR DESCRIPTION OF ANY FUNCTIONALITY, CONDITIONS AND/OR QUALITY OF OUR PRODUCTS OR ANY SUITABILITY FOR A PARTICULAR PURPOSE. WITH REGARD TO THE TECHNICAL SPECIFICATIONS OF OUR PRODUCTS, WE KINDLY ASK YOU TO REFER TO THE RELEVANT PRODUCT DATA SHEETS PROVIDED BY US. OUR CUSTOMERS AND THEIR TECHNICAL DEPARTMENTS ARE REQUIRED TO EVALUATE THE SUITABILITY OF OUR PRODUCTS FOR THE INTENDED APPLICATION.

WE RESERVE THE RIGHT TO CHANGE THIS DOCUMENT AND/OR THE INFORMATION GIVEN HEREIN AT ANY TIME.

Additional information

For further information on technologies, our products, the application of our products, delivery terms and conditions and/or prices, please contact your nearest Infineon Technologies office (www.infineon.com).

Warnings

Due to technical requirements, our products may contain dangerous substances. For information on the types in question, please contact your nearest Infineon Technologies office.

Except as otherwise explicitly approved by us in a written document signed by authorized representatives of Infineon Technologies, our products may not be used in any life-endangering applications, including but not limited to medical, nuclear, military, life-critical or any other applications where a failure of the product or any consequences of the use thereof can result in personal injury.