

# Express-CFR

## COM Express<sup>®</sup> Basic Size Type 6 Module with Hexacore Mobile 9th Gen Intel<sup>®</sup> Xeon<sup>®</sup>, Core<sup>™</sup>, Pentium<sup>®</sup> and Celeron<sup>®</sup> Processors

### Features

- PICMG COM.0 R3.0 Type 6 module with 45W/25W hexacore and quad-core Intel<sup>®</sup> processors
- Up to 96GB\* Dual Channel DDR4 at 2133/2400 MHz in up to three SO-DIMM sockets (\*under validation)
- Three DDI channels, one LVDS, supports up to 3 independent displays (VGA, eDP by build option)
- One PCIe x16 Gen3, eight PCIe x1 Gen3 (NVMe SSD & Intel<sup>®</sup> Optane<sup>™</sup> Memory Technology support)
- GbE, four SATA 6 Gb/s, four USB 3.1 and four USB 2.0
- Supports Smart Embedded Management Agent (SEMA) functions
- Extreme Rugged operating temperature: -40°C to +85°C (build option, selected SKUs)

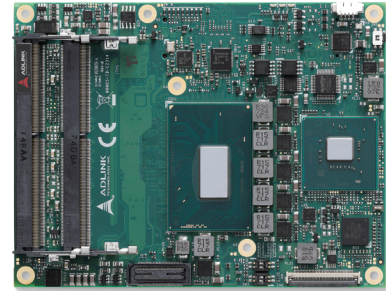

### Specifications

#### Core System

##### CPU

Mobile 9th Generation Intel<sup>®</sup> Xeon<sup>®</sup>, Core<sup>™</sup>, Pentium<sup>®</sup> and Celeron<sup>®</sup> Processors - 14nm process

- Xeon<sup>®</sup> E-2276ME 45W (35W cTDP), 6C/GT2 (ECC/non-ECC)
- Xeon<sup>®</sup> E-2276ML 25W, 6C/GT2 (ECC/non-ECC)
- Xeon<sup>®</sup> E-2254ME 45W (35W cTDP), 4C/GT2 (ECC/non-ECC)
- Xeon<sup>®</sup> E-2254ML 25W, 4C/GT2 (ECC/non-ECC)
- Core<sup>™</sup> i7-9850HE 45W (35W cTDP), 6C/GT2
- Core<sup>™</sup> i7-9850HL 25W, 6C/GT2
- Core<sup>™</sup> i3-9100HL 25W, 4C/GT2 (ECC/non-ECC)
- Pentium<sup>®</sup> G5600E 35W, 2C/GT1 (ECC/non-ECC)
- Celeron<sup>®</sup> G4930E 35W, 2C/GT1 (ECC/non-ECC)
- Celeron<sup>®</sup> G4932E 25W, 2C/GT1 (ECC/non-ECC)

Supports: Intel<sup>®</sup> VT, Intel<sup>®</sup> TXT, Intel<sup>®</sup> SSE4.2, Intel<sup>®</sup> HT Technology, Intel<sup>®</sup> 64 Architecture, Execute Disable Bit, Intel<sup>®</sup> Turbo Boost Technology 2.0, Intel<sup>®</sup> AVX2, Intel<sup>®</sup> AES-NI, PCLMULQDQ Instruction, Intel<sup>®</sup> Secure Key and Intel<sup>®</sup> TSX.

Note: Availability of the features may vary between processor SKUs.

##### Memory

Up to 96GB\* 2133/2400 MHz DDR4 in three SODIMM sockets (\*under validation, max. 48GB verified)

(Xeon<sup>®</sup>, Core<sup>™</sup> i3, Pentium<sup>®</sup>, Celeron<sup>®</sup> paired with CM246 supports both ECC and non-ECC memory)

(three sockets by build option)

##### Embedded BIOS

AMI EFI with CMOS backup in 32/16MB SPI BIOS with Intel<sup>®</sup> AMT 12.0 support

##### Cache

12MB for Xeon<sup>®</sup> 6C, 8MB for Xeon<sup>®</sup> 4C, 9MB for Core<sup>™</sup> i7, 6MB for Core<sup>™</sup> i3, 4MB for Pentium<sup>®</sup>, 2MB for Celeron<sup>®</sup>

#### Chipset

- CM246 (supports ECC memory and Intel<sup>®</sup> AMT)
- QM370 (supports Intel<sup>®</sup> AMT)
- HM370 (no support for Intel<sup>®</sup> AMT)

Note: Chipset is same as Coffee Lake.

#### Expansion Busses

- PCIe x16 or 2 PCIe x8 or 1 PCIe x8 with 2 PCIe x4 (Gen3)
- 6 PCI Express x1 (Gen3); AB connector, Lanes 0/1/2/3/4/5
- 2 PCI Express x1 (Gen3); CD connector, Lane 6/7
- LPC bus, SMBus (system), I<sup>2</sup>C (user)

#### SEMA Board Controller

Supports: voltage/current monitoring, power sequence debug support, AT/ATX mode control, logistics and forensic information, flat panel control, general purpose I<sup>2</sup>C, failsafe BIOS (dual BIOS), watchdog timer and fan control

#### Debug Headers

- 40-pin multipurpose flat cable connector for use with DB-40 debug module providing BIOS POST code LED, BMC access, SPI BIOS flashing, power testpoints, debug LEDs
- 60-pin XDP header for ICE debug of CPU/chipset (optional)

Note: "build option" indicates an alternative BOM configuration to support additional or alternative functions that are not available on the standard product. Be aware that these "build option" part numbers will need to be newly created and this will result in production lead times.

## Specifications

### • Video

#### GPU Feature Support

Intel® Generation 9 LP Graphics Core Architecture, supporting 3 independent and simultaneous display combinations of DisplayPort/HDMI (or VGA), LVDS or eDP outputs

- Hardware encode/transcode HD content (including HEVC 10-bit)
- DirectX 12, DirectX 11.2, DirectX 11.1, DirectX 11, DirectX 10.1, DirectX 10, DirectX 9 support
- OpenGL 4.5 support
- OpenCL 2.1, 2.0/1.2 support

#### Digital Display Interface

DDI1/2/3 supporting DisplayPort 1.2, HDMI 1.4, DVI

Notes:

DP1.2: max. resolution is 4096x2304 @ 60Hz, 24bpp

HDMI1.4: max. resolution is 4096x2160 @ 24Hz, 24bpp

#### VGA

VGA support, in place of DDI3 channel (build option, max. resolution 1920x1200@60Hz)

#### LVDS

Single/dual channel 18/24-bit LVDS from eDP-to-LVDS IC (max. resolution 1920x1200@60Hz in dual mode)

#### eDP

4 lane support optional, in place of LVDS (build option, max. resolution 4096x2304 @60Hz, 24bpp)

### • Audio

Chipset: Intel® HD Audio integrated in chipset

Audio Codec: located on carrier Express-BASE6 (ALC886 standard supported)

### • Ethernet

Intel® I219LM/V with AMT 12.0 support (only LM version support AMT)

Interface: 10/100/1000 GbE connection

### • Multi I/O and Storage

USB: 4x USB 3.1 (USB 0, 1, 2, 3) and 4x USB 2.0 (USB 4, 5, 6, 7)

SATA: Four ports SATA 6Gb/s (SATA0,1,2,3)

Serial: 2 UART ports with console redirection

GPIO/SD: 4 GPO and 4 GPI (GPI with interrupt)

SD/GPIO muxed design, switched by BIOS setting

SD functions as storage device only

Note: USB 3.1 Gen2 support dependent on carrier design

Notes:

\* All specifications are subject to change without further notice.

\* For CPU and chipset combinations not listed, please contact your ADLINK representative for availability.

### • Super I/O

Supported on carrier if needed (standard support for W83627DHG-P)

### • TPM

Chipset: Infineon

Type: TPM 2.0

### • Power

Standard Input: ATX = 12V ±5% / 5Vsb ±5% or AT = 12V ±5%

Wide Input: ATX = 8.5-20 V / 5Vsb ±5% or AT = 8.5-20V

Management: ACPI 5.0 compliant, Smart Battery support

Power States: C1-C6, S0, S1, S3, S4, S5, S5 ECO mode (Wake-on-USB S3/S4, WOL S3/S4/S5)

ECO mode: Supports deep S5 mode for power saving

### • Operating Systems

#### Standard Support

Windows® 10 64-bit, Linux 64-bit, VxWorks 64-bit (TBD)

#### Extended Support (BSP)

Linux 64-bit, VxWorks 64-bit (TBD)

### • Mechanical and Environmental

Form Factor: PICMG COM.0, Rev 3.0 Type 6

Dimension: Basic size: 125 mm x 95 mm

#### Operating Temperature

Standard: 0°C to 60°C

Extreme Rugged: -40°C to +85°C (build option for selected SKUs)

#### Humidity

5-90% RH operating, non-condensing

5-95% RH storage (and operating with conformal coating)

#### Shock and Vibration

IEC 60068-2-64 and IEC-60068-2-27

MIL-STD-202F, Method 213B, Table 213-I, Condition A and Method 214A, Table 214-I, Condition D

#### HALT

Thermal Stress, Vibration Stress, Thermal Shock and Combined Test

## Functional Diagram

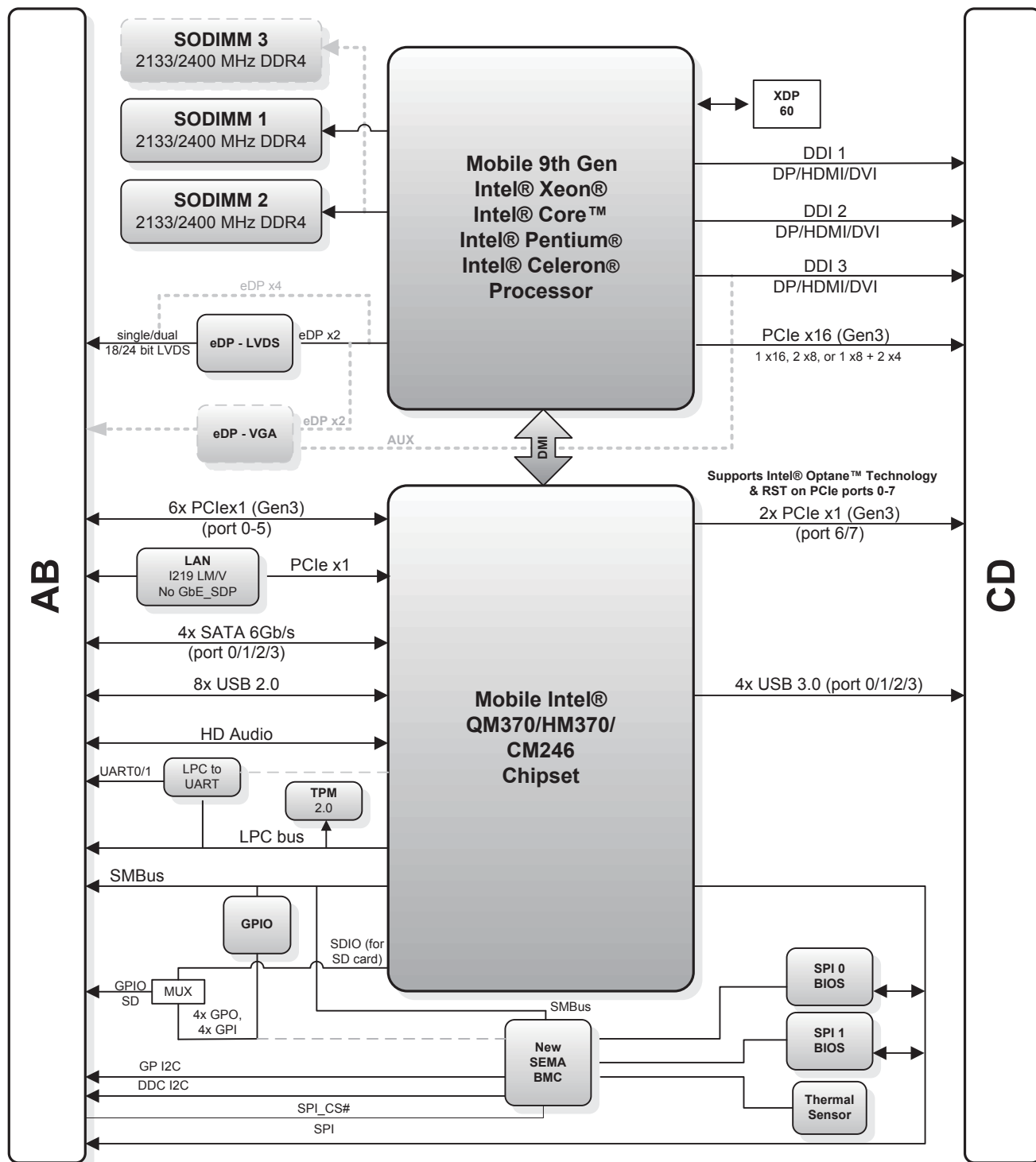

# Express-CFR

---

## Ordering Information

- **Express-CFR-E-2276ME**  
Basic COM Express Type 6 module with Intel® Xeon® E-2276ME (6C/GT2), CM246 chipset, supports ECC/non-ECC
- **Express-CFR-i7-9850HE**  
Basic COM Express Type 6 module with Intel® Core™ i7-9850HE (6C/GT2), QM370 chipset
- **Express-CFR-i3-9100HL**  
Basic COM Express Type 6 module with Intel® Core™ i3-9100HL (4C/GT2), HM370 chipset

SKUs not listed above can be supported by project basis. Please contact your local ADLINK representative.

## Accessories

\* Express-CF and Express-CFR share the same thermal solution

### Heat Spreaders

- **HTS-CF-B**  
Heatspreader for Express-CF/CFE with threaded standoffs for bottom mounting
- **HTS-CF-BT**  
Heatspreader for Express-CF/CFE with through hole standoffs for top mounting

### Passive Heatsinks

- **THS-CF-BL**  
Low profile heatsink for Express-CF/CFE with threaded standoffs for bottom mounting
- **THS-CF-BT**  
Low profile heatsink for Express-CF/CFE with through hole standoffs for top mounting
- **THSH-CF-BL**  
High profile heatsink for Express-CF/CFE with threaded standoffs for top mounting

### Active Heatsink

- **THSF-CF-BL**  
High profile heatsink with Fan for Express-CF/CFE with threaded standoffs for bottom mounting

## Starter Kit

- **COM Express Type 6 Starter Kit Plus**  
Starter kit for COM Express Type 6