

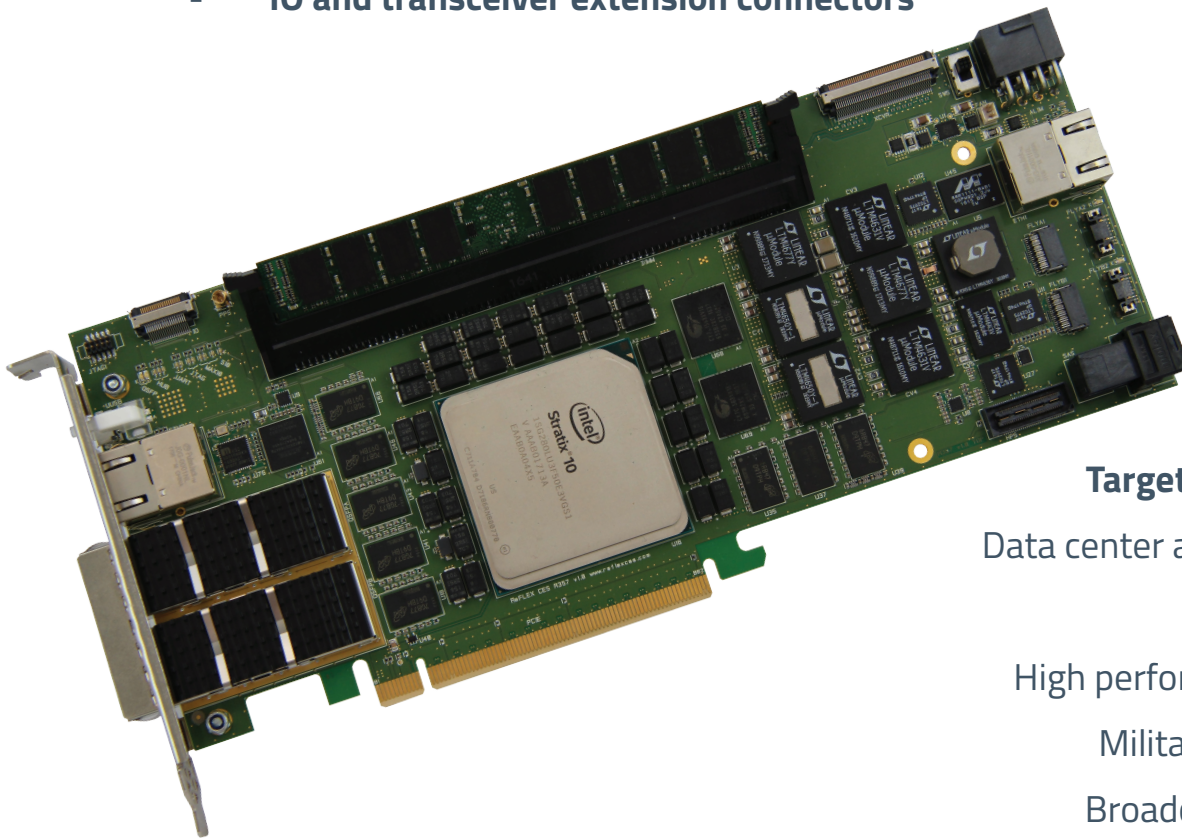

# XpressGX/SX S10-FH200G

Full height profile PCIe Network Processing FPGA board  
Featuring 200G Ethernet

- Full height PCIe board using Intel Stratix 10 GX 2800 KLE
- Designed for Acceleration and Low Latency Applications
- PCIe Gen3 x16, Gen4 x8 capable
- 3 independent banks on board DDR4
- 2 independent banks on board QDR2+Xtrem
- Dual QSFP28 optical cages, 10/25/40/100 GbE ports
- 200G board to board capability (FireFly)
- Board Management Controller (BMC) with IPMI features
- IO and transceiver extension connectors



## Target applications:

Data center and Cloud Computing

Finance

High performance Computing

Military & Defense

Broadcast and video

## Contact :

Europe Sales Office  
sales@reflexces.com

[www.reflexces.com](http://www.reflexces.com)



North America Sales Office  
salesusa@reflexces.com



# XpressGX/SX S10-FH200G

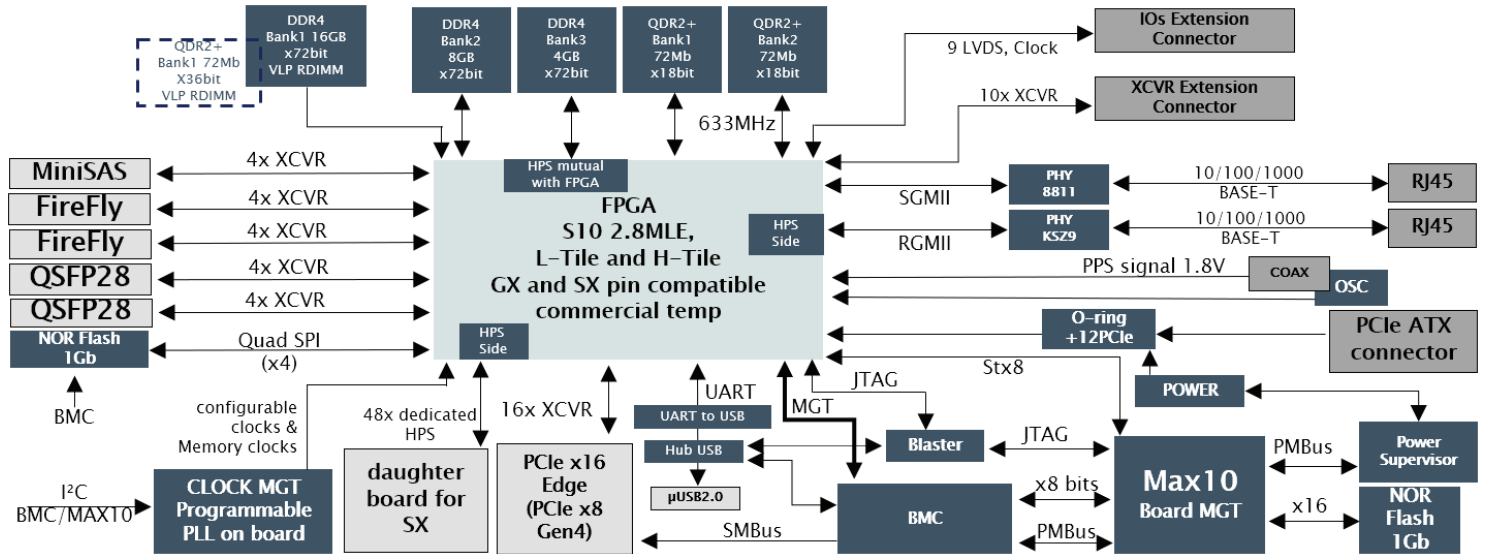

## Full Specifications

### FPGA Configuration

- Stratix 10 GX, L-tile and H-tile compatible
- 10M16SAU16917G MAX10 CPLD
- USB2.0 Micro connector for JTAG, UART and BMC design
- 1x Nor Flash 1GB quad SPI FPGA AS configuration
- 1x Nor Flash 1GB for configuration mode ST8

### Memory

- 1x bank DDR4 VLP RDIMM 25° socket, 16GBytes, x72bit, up to 2400 MT/s \*
- OR 1x bank QDR2+ Xtrem 2 chips 72Mbit, x36bit, up to 550MHz, custom RDIMM on request
- 1x bank DDR4, 8GBytes, x72bit, up to 2400MT/s
- 1x bank DDR4, 4GBytes, x72bit, up to @2133MT/s (HPS), @2400MT/s (FPGA), (HPS bank mutual with FPGA)
- 2 x banks QDR2+ Xtrem 72Mbit each x18bit, up to 550MHz

### Power

- Max 240W, Delivered with a custom 1 slot PCIe passive heat-sink
- 8-pin ATX Power supply connector with Oring protection

Operating Range : 0°C to 40°C

Storage Temp Range : 0°C to 70°C

Board Dimensions : 254mm x 111.15mm

## Deliverables

- Full height 1 slot PCIe board with passive heat-sink and PCIe bracket
- Board Support Package (Manuals, HDL test Designs, Extension connectors FPGA pinout connection)
- 1x DDR4 16 Go 2400 MT/s VLP RDIMM
- Kernel Linux support
- Operating System Support (Software package support for DDR4 SDRAM, eMMC flash, Quad SPI flash, USB host, Gigabit Ethernet, U-boot bootloader and comprehensive user documentation)

## Ordering information

- XpressGXS10L-FH201GT = FPGA Intel Stratix 10 FPGA «Turbo - 26G L-Tile» version, Production
- XpressGXS10H-FH200GTES = FPGA Intel Stratix 10 FPGA «Turbo H-Tile» version, 28 Gb/s FPGA ES
- XpressGXS10H-FH200GT = FPGA Intel Stratix 10 FPGA «Turbo H-Tile» version, 28 Gb/s FPGA Production

Please contact REFLEX CES sales for core/transceiver speed grades

### Communication Interfaces

- PCI Gen3 x16 (Gen4 x8 capable)
- 2x QSFP28 quad optical cage (2 x 4 XCVR : 17 Gb/s, 26 Gb/s or 28 Gb/s per link) connected to 100 Gb/s Ethernet HIP
- 2x FireFly SAMTEC quad connector (17 Gb/s or 28Gb/s each XCVR) - 1 FireFly connected to 100 Gb/s Ethernet HIP
- MiniSAS quad connector (1 HD SAS, 4 SATA HDD, NVMe interface capable)
- GPIO extension connector : 9 LVDS usable as 18 LVCMOS
- XCVR extension connector : 10 XCVR, 8 LVDS, Clock In&Out
- 48 dedicated HPS IO connector (daughter board for SX)

### Other resources

- Programmable PLL oscillator (Si5341), output clocks frequency between 0.0001 MHz to 750 MHz.
- High precision oscillator, clock accuracy 20MHz- 0.05ppm for Precision Time Protocol (PTP) IEEE 1588.
- One coax connector for PPS (pulse per second)
- Max10 USB Blaster on board, UART over USB interface
- Board Management Controller (BMC) for monitoring, EPCQ and clock programming, IPMI features

### Standards and compliance

- RoHS/REACH compliant
- UL certified
- ISO9001 Facility